

# **OL Series 730 Thermoelectrically Cooled Detector Packages**

**Manual No: M000204**

**Revision: G**

**Date: October 2002**



**OPTRONIC LABORATORIES**

A Gooch & Housego Company

**Optronics Laboratories, Inc., 4632 36<sup>th</sup> Street, Orlando, Florida 32811 USA**  
**T +1 407 422 3171 F +1 407 648 5412 E [info@olinet.com](mailto:info@olinet.com)**  
*Visit our website at [olinet.com](http://olinet.com)*

**OL Series 730  
Thermoelectrically Cooled Detector Packages**

**Table of Contents**

INTRODUCTION ..... 1

ELECTRONIC DESIGN ..... 2

    OL 730-TE Cooler Controller ..... 2

    OL Series 730 Detectors ..... 2

        OL 730-Ge Detector ..... 2

        OL 730-HgCdZnTe Detector ..... 2

        OL 730-InGaAs Detector ..... 3

        OL 730-PbS Detector ..... 3

        OL 730-PbSe Detector ..... 3

        OL 730-Si Detector ..... 3

SPECIFICATIONS ..... 4

    OL 730-TE Cooler Controller ..... 4

    OL 730-Ge Detector ..... 4

    OL 730-HgCdZnTe Detector ..... 4

    OL 730-InGaAs Detector ..... 4

    OL 730-PbS Detector ..... 4

    OL 730-PbSe Detector ..... 5

    OL 730-Si Detector ..... 5

    Typical Detector Response Curves ..... 5

OPERATING PROCEDURES ..... 6

MAINTENANCE ..... 9

    Battery Replacement ..... 9

    Cleaning the Chassis ..... 10

    Fuse Replacement ..... 10

    Detector Window ..... 10

    Technical Assistance ..... 10

WARRANTY ..... 11

# OL Series 730 Thermoelectrically Cooled Detector Packages

## INTRODUCTION

The OL 730-Ge, OL 730-HgCdZnTe, OL 730-InGaAs, OL 730-PbS, OL 730-PbSe, and OL 730-Si Thermoelectrically Cooled Detector Packages consist of the OL 730-TE Cooler Controller and the Thermoelectrically Cooled Detector. The OL 730-XXC refers to the calibrated version of the Thermoelectrically Cooled Detector Package.

Circuit assemblies include a thermoelectric controller card located in the OL 730-TE Cooler Controller and detector interface board located in the Thermoelectrically Cooled Detector Head. The OL 730-TE Cooler Controller is capable of accepting any of the Thermoelectrically Cooled Detector Heads. All cooler reference settings are controlled by the detector interface board. This enables the user to purchase several detectors for use with the same OL 730-TE Cooler Controller. Only one detector head may be operated at a time. Figure 1 illustrates the OL 730-TE Cooler Controller with an OL Series 730 detector.

Figure 1 - OL 730-TE Cooler Controller with OL Series 730 Detector

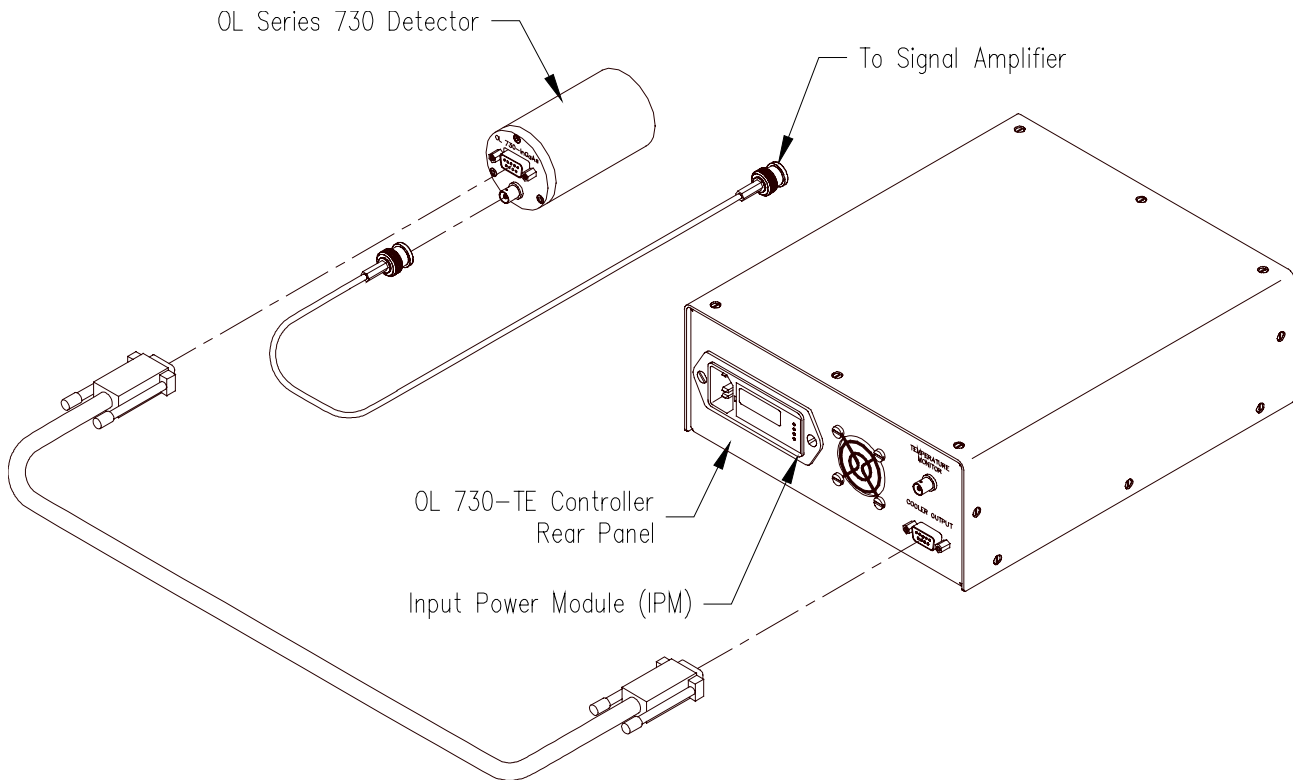

P001013

# ELECTRONIC DESIGN

---

## OL 730-TE Cooler Controller

---

The OL 730-TE Cooler Controller contains a precision temperature controller which supplies a nominal 2.0 Volts to the thermoelectric element at 1.0 amperes. The temperature is precisely controlled by comparing the voltage drop of the biased thermistor to the detectors preset reference that is biased in the same manner. The two voltages are fed to a precision operational amplifier operating as a comparator. The amplifier controls a series pass Darlington transistor that regulates the thermoelectric cooler current. The feedback control produces very stable temperature operation (typ.  $< \pm 0.5$  °C over 24 hours) independent of moderate fluctuations in ambient temperature. Short term temperature stability is  $\pm 0.05$  °C/hour. The OL 730-TE Cooler Controller also contains bias batteries when supplied with either the OL 730-PbS or OL 730-PbSe Detectors. The alkaline batteries are EMI shielded and relay controlled by the power switch. Hardware is included in all cooler controller chassis for field installation of the batteries. A temperature monitor is provided at the cooler chassis rear panel. This enables monitoring of the thermistor voltage (temperature) using a voltmeter. A dual primary transformer and input power module permits rapid conversion of the input power to 120 or 240 VAC. Refer to the *Operating Procedure* section for a detailed description of the input power reconfiguration.

## OL Series 730 Detectors

---

The thermoelectrically cooled OL Series 730 Detectors consists of a TO-8 package with Peltier cooler, thermistor and detector. This TO-8 package is mounted in a 1.875 inch (4.76 cm) diameter machined aluminum housing. The TO-8 package offers a very high detectivity without the inconvenience or bulk of liquid cooling dewars. Each OL Series 730 Detector housing also contains a detector interface PCB. This interface provides precision reference sources that control the reference temperature and thermistor bias. The voltages developed by these temperature compensated current sources are used by the cooler controller to regulate the thermoelectric cooler current. A voltage divider at the TE element is used to drive a transistor in the cooler controller, this transistor acts as a foldback circuit to limit the cooler current to a preset value (typ. 1.3 A). When the detector interface PCB is used with photoconductive detectors, a metal film detector load resistor is included. A high quality film capacitor is used to AC couple the signal dropped across the load resistor.

The black anodized housing provides ample heatsinking for most laboratory applications. Special housings are available for use in harsh environments. However, when the detector is operated for extended periods, the housing will become warm ( $\approx 35$  °C). This occurs primarily at elevated ambient temperatures. Under these conditions, the controller may not be capable of maintaining stable operation and increased heatsinking must be provided. When used in the spectroradiometric mode, the increased heatsinking from the monochromator allows routine operation to 40 °C ambient temperature.

## OL 730-Ge Detector

---

The OL 730-Ge Germanium Detector is a premium quality, high impedance, low capacitance, passivated photodiode operating in a photovoltaic (unbiased) mode. The germanium detector is particularly well suited for measurements in the 800 nm to 1800 nm wavelength region. The germanium diode is mounted with a precision thermistor on a two stage thermoelectric cooler and hermetically sealed with dry nitrogen in a TO-8 package with a glass window.

Typical detectivity is  $5.7 \times 10^{11}$  cm Hz<sup>1/2</sup> W<sup>-1</sup> (Peak, 167 Hz, 1 Hz), at a peak sensitivity of 1.55  $\mu$ m. The response at 1.74  $\mu$ m exceeds 20% of the peak response. The standard operating circuit consists of the germanium detector operated in a common anode. The output may be connected to an operational amplifier configured for current measurement. The detector may also be shunted with a 75 $\Omega$  resistor for monitoring with an oscilloscope. The typical noise level at 167 Hz, with a 1 Hz bandwidth, is  $7.0 \times 10^{-13}$  A corresponding to an infrared flux of approximately  $7.8 \times 10^{-13}$  W.

## OL 730-HgCdZnTe Detector

---

The two stage thermoelectrically cooled OL 730-HgCdZnTe Mercury Cadmium Zinc Telluride Detector consists of a 2 mm x 2 mm photovoltaic detector optically immersed with CdZnTe hemispherical lens. The focal point of the hemispherical lens is 9.85 mm (0.388 inch) from the front surface of the detector housing. The photovoltaic device is optimized for 5  $\mu$ m. The detector, lens, thermistor, and cooler are hermetically sealed in a TO-8 package with a BaF<sub>2</sub> window.

Typical detectivity is  $4 \times 10^{10}$  cm Hz<sup>1/2</sup> W<sup>-1</sup> (Peak, 10 KHz, 1 Hz), at a peak sensitivity of 4.5  $\mu$ m. The response at 5.5  $\mu$ m exceeds 20% of the peak response.

### CAUTION:

This device is extremely sensitive to static discharge! The BNC shorting cap should be used whenever the detector is not in use.

## OL 730-InGaAs Detector

---

The thermoelectrically cooled OL 730-InGaAs Indium Gallium Arsenide Detector consists of a high impedance, planar photodiode mounted with a thermistor on a single stage thermoelectric cooler. These detectors are particularly well suited for use in systems operating in the 0.8  $\mu\text{m}$  to 1.8  $\mu\text{m}$  spectral range. The 3 mm diameter InGaAs detector is mounted in a hermetically sealed TO-8 package with a sapphire window.

Typical detectivity is  $1.6 \times 10^{12} \text{ cm Hz}^{1/2} \text{ W}^{-1}$  (Peak, 167 Hz, 1 Hz), at a peak sensitivity of 1.6  $\mu\text{m}$ . The response at 1.72  $\mu\text{m}$  exceeds 20% of the peak response. The standard operating circuit consists of the InGaAs detector operated in a common anode. The output may be connected to an operational amplifier configured for current measurement. The detector may be shunted with a 75 $\Omega$  resistor for monitoring with an oscilloscope. The typical noise level at 167 Hz, with a 1 Hz bandwidth, is  $1.5 \times 10^{-13} \text{ A}$  corresponding to an infrared flux of approximately  $1.7 \times 10^{-13} \text{ W}$ .

## OL 730-PbS Detector

---

The thermoelectrically cooled OL 730-PbS Lead Sulfide Detector consists of a chemically deposited thin film, photo-conductive, lead sulfide cell mounted with a thermistor on a single stage thermoelectric element. These detectors are particularly well suited for use in systems operating in the 1  $\mu\text{m}$  to 3  $\mu\text{m}$  spectral range. The 3 mm x 3 mm PbS detector is mounted in a hermetically sealed TO-8 package with a sapphire window.

Typical detectivity is  $2.1 \times 10^{11} \text{ cm Hz}^{1/2} \text{ W}^{-1}$  (Peak, 167 Hz, 1 Hz), at a peak sensitivity of 2.5  $\mu\text{m}$ . The response at 3  $\mu\text{m}$  exceeds 20% of the peak response. The standard operating circuit consists of the detector in series with a load resistor and a bias battery, with the AC coupled output signal monitored across the load resistor. The typical noise level at 167 Hz, with a 1 Hz bandwidth, is 0.5  $\mu\text{V}$  corresponding to an infrared flux of approximately  $1.4 \times 10^{-12} \text{ W}$ . The PbS detectors performs best when used in a direct radiometric substitution mode of measurement where the unknown detector is directly compared to a standard. The optical configuration of the test system should be similar to the calibration setup given in the calibration report.

## OL 730-PbSe Detector

---

The OL 730-PbSe Lead Selenide Detector consists of a chemically deposited thin film, photo-conductive, lead selenide cell mounted with a thermistor on a single stage thermoelectric module. These detectors are particularly well suited for use in systems operating in the 1  $\mu\text{m}$  to 5  $\mu\text{m}$  spectral range. The 3 mm x 3 mm PbSe detector is mounted in a hermetically sealed TO-8 package with a sapphire window. The PbSe TO-8 package is mounted in a 3.25 inch (8.26 cm) diameter machined aluminum housing.

Typical detectivity is  $1.9 \times 10^9 \text{ cm Hz}^{1/2} \text{ W}^{-1}$  (Peak, 167 Hz, 1 Hz), at a peak sensitivity (4.4  $\mu\text{m}$ ). The response at 5.2  $\mu\text{m}$  exceeds 20% of the peak response. The standard operating circuit consists of the detector in series with a load resistor, across the bias battery, with the AC coupled output signal monitored across the PbSe cell. A typical noise level at 167 Hz, with a 1 Hz bandwidth, is 0.5  $\mu\text{V}$  corresponding to an infrared flux of  $1.5 \times 10^{-10} \text{ W}$ . The PbSe detector performs best when used in a direct radiometric substitution mode of measurement where the unknown detector is directly compared to a standard. The optical configuration of the test system should be similar to the calibration setup given in the calibration report.

## OL 730-Si Detector

---

The thermoelectrically cooled OL 730-Si Silicon Detector consists of a 5.8 mm x 5.8 mm, high impedance, low capacitance, UV enhanced, planar diffusion photodiode. The silicon detector provides excellent sensitivity over the 0.2  $\mu\text{m}$  to 1.1  $\mu\text{m}$  wavelength region. The photodiode exhibits superior uniformity over the entire active area. The OL 730-Si is capable of linear operation over 13 decades of dynamic range. Thermal stability of 0.1 %/ $^{\circ}\text{C}$  for wavelengths below 1  $\mu\text{m}$  is typical. The TO-8 package is mounted in a 3.25 inch diameter machined aluminum housing.

Typical detectivity is  $3 \times 10^{13} \text{ cm Hz}^{1/2} \text{ W}^{-1}$  (Peak, 167 Hz, 1 Hz), at a peak wavelength of 960 nm. The typical noise level at 167 Hz, with a 1 Hz bandwidth, is  $5 \times 10^{-15} \text{ ampere}$ .

# SPECIFICATIONS

---

## OL 730-TE Cooler Controller

---

Input Power .....	120 or 220 VAC (User Selectable)
Power Consumption.....	0.3 A 120 VAC, 0.15 A 220 VAC
Fuse.....	0.5 A (fast blow)
Temperature Control Range (Detector Dependent).....	-40 °C to 10 °C
Ambient Operating Temperature Range.....	15 °C to 30 °C
Foldback Threshold .....	2.5 V
TE Output Ripple (Maximum).....	10 mV p.p.
Bias Voltage (OL 730-PbS and OL 730-PbSe only).....	-64 V ±4 V
TE Voltage .....	2.0 V
TE Current.....	1.5 A

## OL 730-Ge Detector

---

Operating Temperature (Nominal).....	-25 °C
Active Area .....	5 mm diameter
Spectral Range .....	.8 µm to 1.8 µm
Peak Responsivity (Nominal).....	.90 A/W
NEP (Nominal) .....	1 x 10 <sup>-12</sup> W @ 1.5 µm
Output Impedance (Nominal).....	2 MΩ (-20 °C)
Frequency Response (50 Ω Load @ Max. Vreverse).....	DC to ≈100 kHz
Max. Reverse Voltage .....	0.25 Volt
Capacitance (@ Vreverse = 0 V) .....	36 nF

## OL 730-HgCdZnTe Detector

---

Operating Temperature (Nominal).....	-40 °C
Active Area .....	2 mm x 2 mm
Spectral Range .....	2 µm to 5.5 µm
Peak Responsivity (Nominal).....	≥ 290 V/W
NEP (Nominal) .....	1 x 10 <sup>-12</sup> W @ 4 µm
Output Impedance (Nominal).....	150 Ω (-45 °C)
Response Time (Nominal).....	< 20 ns

## OL 730-InGaAs Detector

---

Operating Temperature (Nominal).....	-30 °C
Active Area .....	3 mm diameter
Spectral Range .....	.8 µm to 1.8 µm
Peak Responsivity.....	.9 A/W
NEP (Nominal) .....	1.7 x 10 <sup>-13</sup> W @ 1.6 µm
Output Impedance.....	20 MΩ (-30 °C)
Frequency Response (Nominal).....	DC to >200 kHz

## OL 730-PbS Detector

---

Operating Temperature (Nominal).....	-10 °C
Active Area .....	3 mm x 3 mm
Spectral Range .....	1 µm to 3.0 µm
Peak Responsivity.....	3.5 x 10 <sup>5</sup> V/W
NEP (Nominal) .....	1.5 x 10 <sup>-13</sup> W @ 2.6 µm
Detector Impedance (Nominal).....	2 MΩ (-10 °C)
Output Impedance (Nominal).....	1 MΩ
Frequency Response (Nominal).....	DC to ≈10 kHz

## OL 730-PbSe Detector

Operating Temperature (Nominal)	-10 °C
Active Area	3 mm x 3 mm
Spectral Range	1 μm to 6 μm
Peak Responsivity	3.2 x 10 <sup>3</sup> V/W
NEP (Nominal)	1.5 x 10 <sup>-10</sup> W @ 4.4 μm
Detector Impedance (Nominal)	2 MΩ (-10 °C)
Output Impedance (Nominal)	1 MΩ
Frequency Response (Nominal)	DC to ≈10 kHz

## OL 730-Si Detector

Operating Temperature (Nominal)	5 °C
Active Area	5.8 mm x 5.8 mm (0.3364 cm <sup>2</sup> )
Spectral Range	0.2 μm to 1.1 μm
Peak Responsivity	0.5 A/W
NEP (Nominal)	1 x 10 <sup>-15</sup> W @ 0.96 μm
Detector Impedance (Nominal)	10 GΩ
Frequency Response (Nominal)	DC to 1 MHz

## Typical Detector Response Curves

OL Series 730-TE Thermoelectrically Cooled Detector Packages  
Detector Responsivities

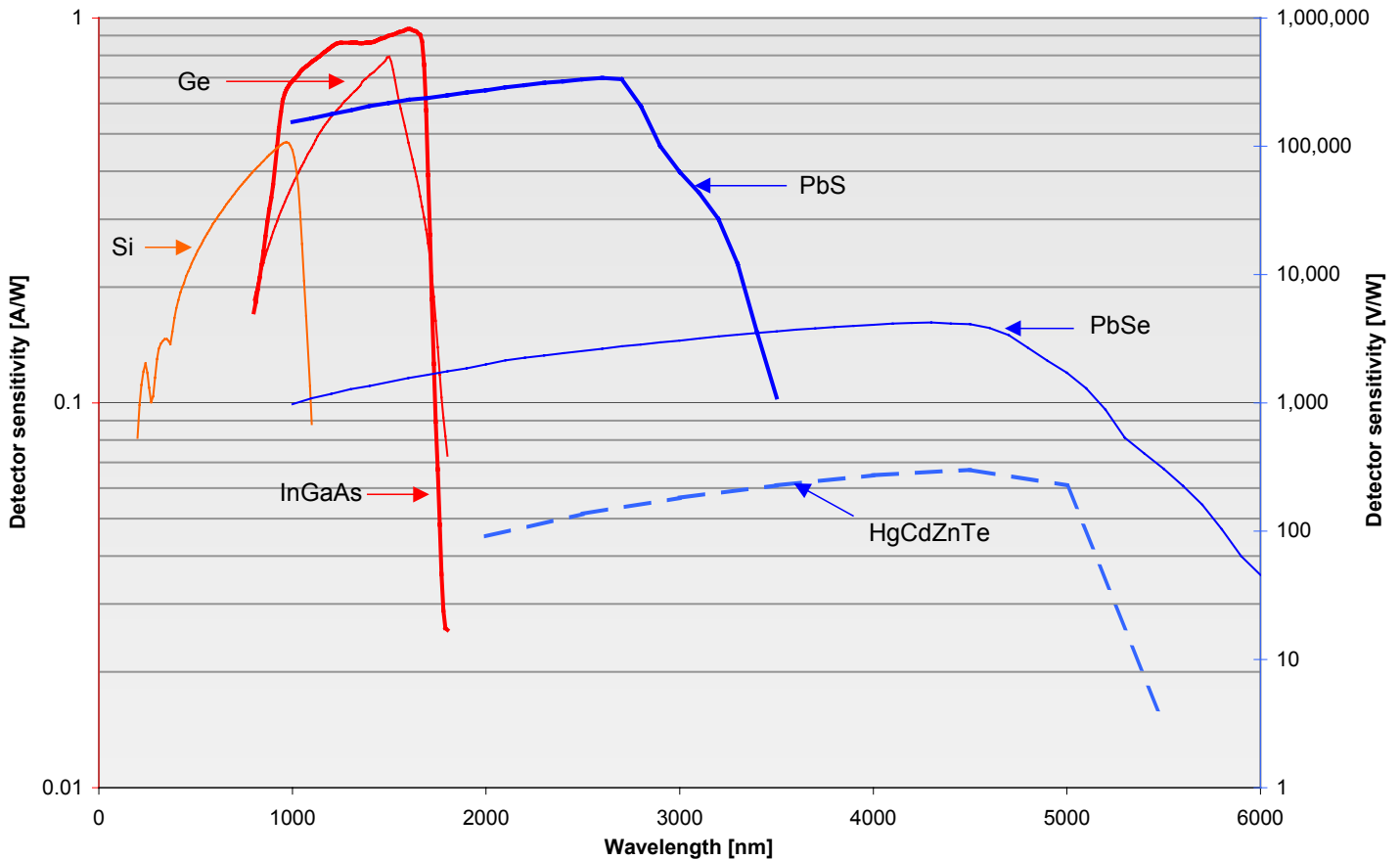

# OPERATING PROCEDURES

**NOTE:**

The two 30 Volt bias batteries have approximately 1 year of life in this circuit. Check and replace as necessary with Eveready No. 413 / Neda #210. Refer to the *Maintenance* section for instructions regarding battery testing and replacement.

1. Verify that the Input Power Module (IPM) is configured for the input power source. The input power selection is visible at the Input Power Module on the rear panel of the OL 730-TE Controller.

To change the input power voltage setting, remove the power cord. Pry of the plastic front cover of the Input Power Module by inserting a small flat blade screwdriver. Remove the Fuse Block from the IPM. Use a small pair of pliers to remove the PCB. It is important to note the direction and orientation of the PCB, so that it can be re-inserted in the same manner. Slide the plastic voltage indicator around the PCB until it is **opposite** of the desired voltage. The plastic indicator should be seated in the notch at the edge of the PCB. Refer to Figure 2. Re-insert the PCB. A positive snap will indicate that the PCB is seated properly.

Figure 2 - Input Power Module Setting

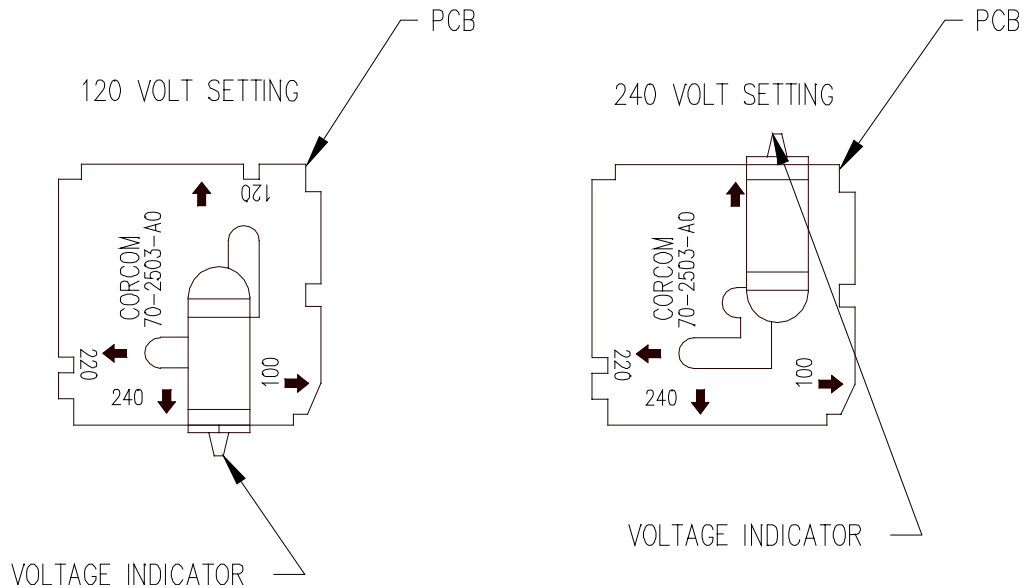

P001151

To change the fuse arrangement, rotate the Fuse Block for the desired voltage. (Remove the screw that is used to fasten the Fuse Block to the IPM cover.) Note for 240 VAC, the side which holds two fuses is positioned up. For 240 VAC operation, an additional 250 VAC 0.5 A fast blow fuse is required in the Fuse Block. (Refer to Figure 3). Reattach the Fuse Block to the IPM cover. Reattach the IPM front cover and re-insert the power cord.

Figure 3 - Fuse Changing

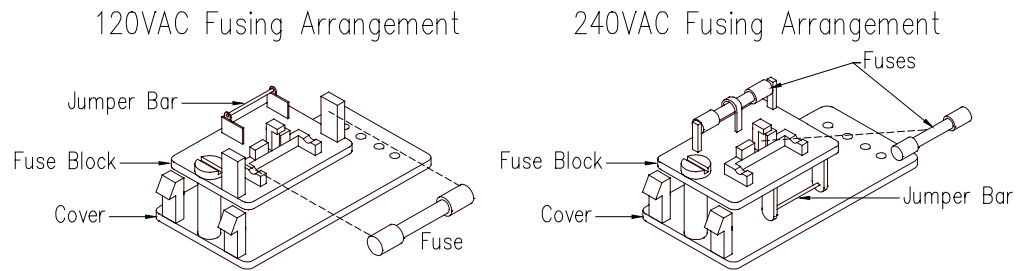

P001126



2. Once the Input Power Module is configured to the proper power voltage, verify that the power switch is in the OFF position before connecting any cables to the OL 730-TE Cooler Controller.
3. Plug the OL 730-TE Cooler Controller Chassis into an appropriate AC socket. **Always turn off the OL 730-TE Cooler Controller power before adding or removing a detector head.**
4. Connect the “D” subminiature Cooler Output connector of the OL 730-TE Cooler Controller to the OL Series 730 Detector using the cable provided (refer to Figure 1). Never use a damaged controller cable or BNC cable with an OL 730-TE Cooler Controller or OL Series 730 Detector Head. Always use the connector screws and thumbscrews to fasten the cooler cable to the OL 730-TE Cooler Controller and OL Series 730 Detector. The backshells provide grounding between the OL 730-TE and OL Series 730 Detector housings and are necessary for optimum performance. Never force cables to bend beyond their normal flexibility, especially near the connector strain relief.
5. Connect a coaxial cable from the OL Series 730 Detector BNC connector to the OL 730D Lock-In Amplifier or other suitable amplifier.

When using the OL 730-HgCdZnTe detectors, touch the BNC cable connector to the detector shorting cap before removing the shorting cap from the OL 730-HgCdZnTe BNC connector. The OL 730-HgCdZnTe is very sensitive to electrostatic discharge. For the OL 730-HgCdZnTe amplifiers shown below, R should be at least five times  $R_D$  (150  $\Omega$  typical).

*Typical OL 730-HgCdZnTe Amplifier*

**OL 730-HgCdZnTe DETECTOR**

**CAUTION !**

- CW optical power must not exceed 20 W/cm<sup>2</sup> !
- Pulses shorter than 1  $\mu$ s must not exceed 10 kW/cm<sup>2</sup> !
- Avoid steady-state or transient overbiasing of detector !

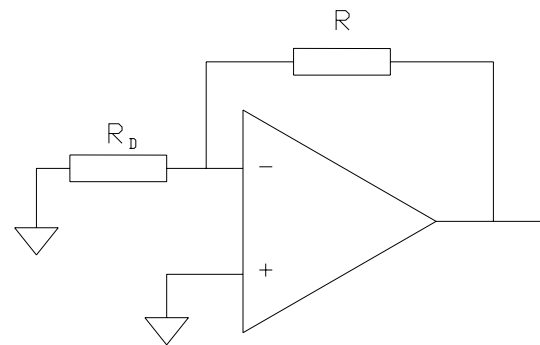

6. When using the OL 730-PbS Detector, remove the cap from the OL 730-PbS Detector and mount the detector module at the exit slit of monochromator or into an appropriate optical attachment.

**NOTE:**

To avoid the phenomena of detector “FLASHING”, the PbS detector should not be exposed to sources of ultraviolet radiation. This includes intense sources, room light and flashlights. Exposure to ultraviolet light results in a temporary reduction in the dark resistance, responsivity and detectivity. The detector should be covered when not mounted in a monochromator to prevent this undesirable UV influence. This flashing effect may be reversed by storing the detector in a dark environment for 24 hours. To avoid this phenomena, the detector should be handled under low light conditions at all times (i.e., less than 15 footcandles). Avoid direct light from flashlights, fluorescent lamps or other UV rich light sources.

7. Turn the OL 730-TE Cooler Controller power on using the front panel power switch.
8. Allow 15 minutes for the detector to stabilize to the preset operating temperature. A voltmeter may be used to monitor the detector temperature. Connect the meter to the Temperature Monitor BNC connector on the OL 730-TE Cooler Controller rear panel. Refer to the Table A below for the voltage monitor conversion formula that corresponds to the detector in use.

**NOTE:**

The OL 730 detector serial number should be used to reference the correct conversion equation. These changes are necessary to reflect detector circuit changes required achieving the specified operating temperature. The changes are also to accommodate thermistor variations and address thermistor power dissipation.

**Table A**

Detector	Serial Number	Temperature Monitor Conversion	Distance from the detector element to the detector housing. (Distance "A" in Figure 4)
OL 730-Ge	XX200XXX	$25 - [(\log(V_{\text{mon}} / 100 \mu\text{A}) - 3.18) / 0.0165]$	0.138 inch (3.50 mm)
OL 730-HgCdZnTe	XX100XXX	$24 - [(\log(V_{\text{mon}} / 25 \mu\text{A}) - 3.299) / 0.01939]$	0.250 inch (6.35 mm)
OL 730-InGaAs	XX100XXX	$24 - [(V_{\text{mon}} - 0.17) / 0.02278]$	0.120 inch (3.05 mm)
OL 730-InGaAs	XX101XXX	$25 - [(\log(V_{\text{mon}} / 25 \mu\text{A}) - 3.9542) / 0.019014]$	0.156 inch (3.96 mm)
OL 730-InGaAs	XX102XXX	$25 - [(\log(V_{\text{mon}} / 25 \mu\text{A}) - 3.176) / 0.02593]$	0.120 inch (3.05 mm)
OL 730-PbS	XX100XXX	$25 - [\log(V_{\text{mon}} / 100 \mu\text{A}) - 3.111] / 0.01728]$	0.214 inch (5.44 mm)
OL 730-PbSe	XX100XXX	$25 - [\log(V_{\text{mon}} / 100 \mu\text{A}) - 3.111] / 0.01728]$	0.214 inch (5.44 mm)
OL 730-Si	XX100XXX	$30 - [(\log(V_{\text{mon}} / 25 \mu\text{A}) - 3.8751) / 0.018749]$	0.227 inch (5.77 mm)

**NOTE:**

Connecting the OL Series 730 Detector to the OL 730D Lock-In Amplifier prior to temperature stabilization may cause the OL 730D Lock-In Amplifier to saturate due to fluctuations in the detector resistance. This condition is normal and will create an overload that will be sensed by the OL 730D Lock-In Amplifier. Higher amplifier gain setting will increase the probability of an overload. This phenomena will dissipate prior to the 15 minute stabilization time.

- Before performing measurements, refer to Figure 4 when aligning and positioning the detector. Distance "A", given in Table A above, is the distance from the detector element to the front of the detector housing.

*Figure 4 - Distance "A" is the distance from the detector element to the front of the detector housing*

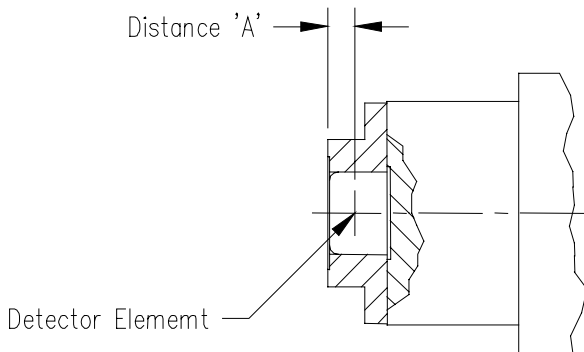

P001313

- Always store unused OL 730-PbS and OL 730-PbSe detectors in a dark environment to inhibit changes in response due to exposure.

# MAINTENANCE

## Battery Replacement

The bias battery may be tested in the field using a voltmeter capable of measuring 60 volts DC. Disconnect the OL Series 730 Detector Head from the OL 730-TE Cooler Controller. With the power switch turned off, connect the voltmeter to pins 5 and 9, reference pin 9. Switch the power on. Bias voltage should be  $-64$  volts DC  $\pm 4$  V. The batteries should be replaced when the voltage is less than 60 volts and annually.

To replace the bias batteries, disconnect the AC power and remove the cover. The batteries are located under a yellow iridated aluminum EMI shield on the left side of the cooler controller PCG. Remove the screws from the EMI shield. Remove the retainer from the battery clip and remove the old batteries. Replace the batteries with Eveready #413 / Neda #210. Do not spring battery clip when installing batteries. Place the retainer on the battery clip, and cover with the EMI shield.

Figure 5 - OL 730-TE Cooler Controller Battery Replacement

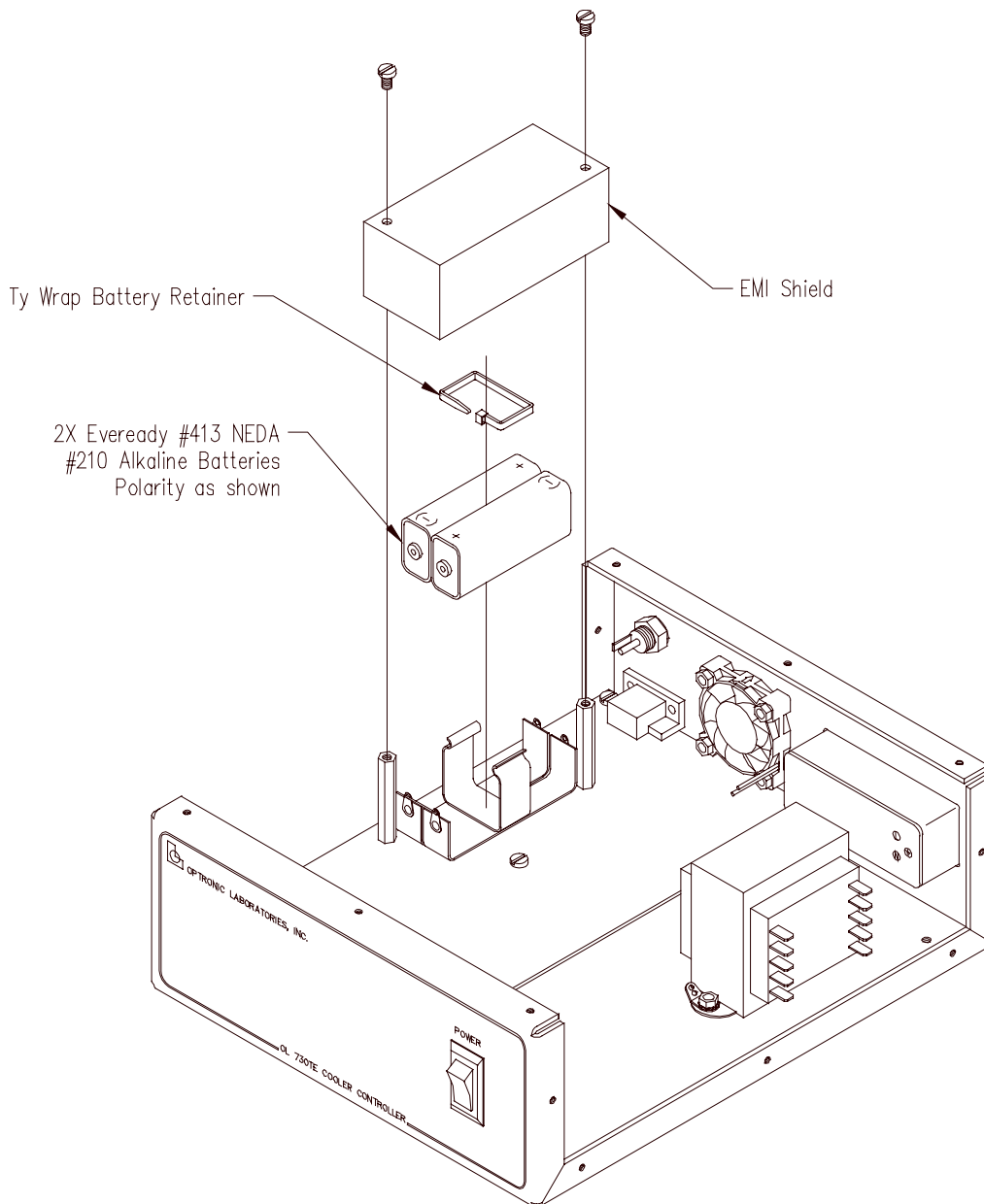

P001013A

It is recommended that calibrated detectors be returned to Optronic Laboratories for recalibration annually. A system evaluation is also recommended for detectors that experience frequent use at two year intervals.

## Cleaning the Chassis

---

When cleaning the OL 730-TE Cooler Controller:

1. The power must be turned off for a least 1 minute before cleaning.
2. Use only a cloth moistened with water.
3. Do not allow water to get inside the chassis.
4. Do not clean the connectors on the rear panel.

## Fuse Replacement

---

The OL 730-TE Cooler Controller uses only fuses that comply with IEC 127.

- (1) 115 VAC operation: 0.75A, T (1¼ x ¼ inch dia Type 3AG)
- (2) 220 VAC operation: 0.315A, F Fast Blow (5 x 20 mm)

## Detector Window

---

Never touch the window of the OL Series 730 Detector Head. Oils from fingers can permanently blemish the detector optics. The OL Series 730 Detectors should be handled with utmost care. If a detector window is touched, immediately clean the surface. Use a cotton applicator and a small amount of isopropyl alcohol. Very gently, with light circular strokes, clean the entire window. Remove any excess alcohol using a pressurized dry air spray. Do not allow the cleansing agent to remain on the OL Series 730 Detector window, this may encourage disintegration of the seal between the window and metal package. Extreme care should be taken to avoid pressing on the window as the hermetic seal of the detector can be destroyed.

**\*\* CAUTION \*\***

Do not use acetone or halogenated solvents, these agents will permanently damage some optical surfaces.

Avoid exposure of the system to excessive moisture such as green houses. Continued exposure to humid environments will accelerate the deterioration of electrical components and interconnections. When measurements are made in such environments, protective enclosures should be considered to ensure consistent performance of the system.

## Technical Assistance

---

If there is any uncertainty about how to install and operate the OL Series 730 Thermoelectrically Cooled Detector Package, technical assistance can be received by contacting:

Optronic Laboratories, Inc.  
4632 36<sup>th</sup> Street  
Orlando, Florida 32811 USA  
Phone: 407 422 3171  
Fax: 407 648 5412  
Website: <http://www.olinet.com>

## **WARRANTY**

---

Optronic Laboratories warrants the items delivered hereunder to free from defects in material and workmanship and to conform to current Optronic Laboratories specifications at the time of sale. Purchaser shall have a period of one year from date of acceptance of the items to return deficient items to Optronic Laboratories for correction. Material will be considered accepted 30 days after receipt by purchaser unless Optronic Laboratories is notified of acceptance earlier.

Optronic Laboratories agrees to repair or replace at the place of manufacture, without charge, all items returned, transportation prepaid, for inspection at Optronic Laboratories within the warranty period, provided that: 1) such inspection discloses to the satisfaction of Optronic Laboratories that the defects are as above specified and 2) the material has not been subjected to misuse, improper maintenance, negligence or accident, damage by excessive radiation, voltage, current or otherwise.

The item returned shall only be accepted when accompanied by a written statement setting forth the nature and suspected of the alleged deficiencies.

This warranty is expressly in lieu of all other warranties, expressed, implied or statutory, and all other obligations or liabilities on the part of Optronic Laboratories. In no event shall Optronic Laboratories be liable for claims, demands or damages of any nature, however, denominated, except that Optronic Laboratories' liability shall be to repair defective items at its factory or supply replacement parts in accordance with the terms of this warranty. When equipment is shipped FOB Orlando, Florida, and when said equipment fails to perform according to specifications upon receipt, a claim should be made immediately against the shipping agency.